

Grove RT890E

Product Guide



Features

- 80 t (90 USt) capacity
- 11,4 m – 43,2 m (38 ft – 142 ft) five-section, full power boom
- 10 m – 17 m (33 ft – 56 ft) offsettable bi-fold lattice, swingaway extension
- 4,8 m (16 ft) or 9,7 m (32 ft) extension inserts
- Grove MEGAFORM™ boom
- 9979 kg (22,000 lb) counterweight hydraulically installed and removed



Features

Removable counterweight

Counterweight and auxiliary hoist is hydraulically removed/installed for easier hauling from job to job.



Power luffing extension

For improved up-and-over reach, a power luffing extension is available on the RT890E and hydraulically offsets from the super-structure cab from 5° to 40°.



Cab

The Full Vision cab on the RT890E tilts up to 20° providing the operator additional comfort when working at long boom and extension lengths.

CraneSTAR

CraneSTAR is an exclusive and innovative crane asset management system that helps improve your profitability and reduce costs by remotely monitoring critical crane data. Visit www.cranestar.com for more information.



Boom

The RT890E is equipped with a 11,4 m - 43,2 m (38 ft - 142 ft) five-section, full power boom. The Grove MEGAFORM™ boom shape eliminates weight and increases capacity compared to conventional shapes.

Contents

| | |
|--|----|
| Features | 2 |
| Specifications | 4 |
| Dimensions and weights | 7 |
| Working range | 8 |
| Mode A vs. (Mode B) | 9 |
| Load chart (Mode B) | 10 |
| Load chart fixed offsettable swingaway | 11 |
| Working range with one 16 ft insert | 12 |
| Working range with two 16 ft inserts | 13 |
| Load charts fixed offsettable swingaway with inserts | 14 |
| Load charts (Mode A) | 15 |
| Luffing extension charts | 17 |
| Load handling | 21 |

Specifications

Superstructure



Boom

11,4 m – 43,2 m (38 ft – 142 ft) five-section, sequenced synchronized full power boom with A and B mode.

Maximum tip height: 45,7 m (150 ft).



*Optional lattice extension

10 m – 17 m (33 ft – 56 ft) offsettable bi-fold lattice swingaway extension. Offsets 0°, 20° and 40°. Stows alongside base boom section.

Maximum tip height: 62,7 m (206 ft).



*Optional lattice extension

10 m – 17 m (33 ft – 56 ft) hydraulically offsettable bi-fold lattice swingaway extension. Offsets from 0° to 40°. Stows alongside base boom section.

Maximum tip height: 62,7 m (206 ft).



*Optional lattice extension inserts

(2) x 4,8 m (16 ft) lattice extension inserts. Installs between the boom nose and bi-fold extension, non-stowable.

Maximum tip height: 72,5 m (238 ft)



Boom nose

Five nylatron sheaves mounted on heavy duty tapered roller bearings with removable pin-type rope guards. Quick reeving type boom nose. Removable auxiliary boom nose with removable pin type rope guard.



Boom elevation

One double acting hydraulic cylinder with integral holding valve provides elevation from -3° to +78°.



Load moment and anti-two block system

Standard “Graphic Display” load moment and anti-two block system with audio-visual warning and control lever lockout. These systems provide electronic display of boom angle, length, radius, tip height, relative load moment, maximum permissible load, load indication and warning of impending two-block condition. The standard Work Area Definition System allows the operator to pre-select and define safe working areas. If the crane approaches the pre-set limits, audio-visual warnings aid the operator in avoiding job-site obstructions.



Cab

20° tilt, Full-vision, all-steel fabricated with acoustical lining and tinted safety glass throughout. Deluxe seat incorporates armrest-mounted hydraulic single-axis controllers. Tilt/telescoping steering wheel with various controls incorporated into the steering column. Other standard features include: hot water heater, cab circulating air fan, sliding side and rear windows, sliding skylight with electric wiper and sunscreen, electric windshield wash/wipe, fire extinguisher, seat belt, air conditioning, and dual cab mounted work lights.



Swing

Two speed, planetary swing drive with foot applied multi-disc wet brake. Spring applied, hydraulically released swing brake. Single position mechanical house lock, operated from cab. Maximum speed: 2.0 rpm.



Counterweight

9979 kg (22,000 lb). Hydraulically installed and removed.

Specifications

Superstructure (continued)



Hoist specifications (HP30-18G) main and auxiliary hoist

Planetary reduction with automatic spring applied multi-disc wet brake. Electronic hoist drum rotation indicators, and hoist drum cable followers.

Maximum single line pull:

1st layer: 9185 kg (20,250 lb)

3rd layer: 7715 kg (17,010 lb)

5th layer: 6650 kg (14,660 lb)

Maximum permissible line pull:

7620 kg (16,800 lb) with 35x7 class rope

Maximum single line speed: 156 m/min (514 fpm)

Rope construction:

35x7 rotation resistant

Rope diameter: 19 mm (3/4 in)

Rope length:

Main hoist: 182 m (600 ft)

Auxiliary hoist: 182 m (600 ft)

Maximum rope stowage: 256 m (841 ft)

Carrier



Chassis

Box section frame fabricated from high-strength, low alloy steel. Front/rear towing and tie down lugs.



Outrigger system

Four hydraulic telescoping single-stage double box beam outriggers with inverted jacks and integral holding valves. Three position setting, 0%, 50% and fully extended. Outrigger monitoring comes standard.

All steel fabricated, quick release type outrigger floats, 775 mm (30.5 in) diameter.

Maximum outrigger pad load: 56 700 kg (125,000 lb).



Hydraulic system

Two main pumps ([1] piston and [1] gear) with a combined capacity of 503 LPM (133 GPM).

Maximum operating pressure: 277.7 bar (4000 psi).

Three section pressure compensated valve bank.

Return line type filter with full flow by-pass protection and service indicator. Replaceable cartridge with micron filtration rating of 5/12/16. 959 L (253

gallon) hyd. reservoir. Carrier mounted oil cooler with thermostatically controlled hydraulic motor driven fan/air to oil. System pressure test ports.



Outrigger controls

Controls and crane level indicator located in cab.



Engine (Tier IVF)

Cummins QSB 6.7L diesel, six-cylinder, turbo-charged. 205 kW (275 hp) at 2500 rpm.

Meets emissions per U.S. E.P.A., Tier IV Final and E.U. Stage IV.

Maximum torque: 987 Nm (728 ft/lb) at 1500 rpm.

Fuel requirement: Minimum of 15 ppm sulphur content (Ultra Low Sulphur Diesel Fuel and Diesel Exhaust Fluid (DEF))

Note: Tier IVF engine required in North American, Canadian, and European Union countries.



Engine (Tier III)

Cummins QSB 6.7 L diesel, six cylinders, turbo-charged, 205 kW (275 bhp) (Gross) at 2500 rpm.

Maximum torque: 987 Nm (728 ft/lb) at 1500 rpm.

Note: Required for sale outside of North American and European Union countries.



Fuel tank capacity

280 L (74 gal)



Transmission

Full rangeshift with 6 forward and 6 reverse speeds.

Front axle disconnect for 4 x 2 travel.



Electrical system

Three 12 V - maintenance free batteries.

12 V starting and lighting. Battery disconnect. CanBus Diagnostic system.

Specifications

Carrier (continued)

Drive

4 x 4.



Steering

Fully independent power steering:

Front: Full hydraulic steering wheel controlled.

Rear: Full hydraulic switch controlled.

Provides infinite variations of 4 main steering modes: front only, rear only, crab and coordinated.

Rear steer indicator.

Turning radius: 7,3 m (24 ft)



Axles

Front: Drive/steer with differential and planetary reduction hubs rigid mounted to frame.

Rear: Drive/steer with differential and planetary reduction hubs pivot mounted to frame.



Oscillation lockouts

Automatic full hydraulic lockouts on rear axle permits 25,4 cm (10 in) oscillation only with boom centered over the front.



Brakes

Full hydraulic split circuit operating on all wheels. Spring-applied, hydraulically released parking brake mounted on front axle.



Tires

Standard 29.5 x 25 - 34 bias ply, Titan



Lights

Full lighting including turn indicators, head, tail, brake and hazard warning lights.



Maximum speed

35 km/h (22 mph)



Gradeability (theoretical)

75%

(Based on 52 607 kg [115,976 lb] GVW, 29.5 x 25 tires, 43,2 m [142 ft] boom, plus 17,0 m [56 ft] swingaway, 22,000 lb counterweight, 80 t [90 USt] hookblock and 9,1 t [10 USt] headache ball).

Miscellaneous standard equipment

Full width steel fenders, full length aluminum decking, dual rear view mirrors, hook-block tie down, electronic back-up alarm, light package, front stowage well, cab air conditioning, tachometer/hourmeter, rear wheel position indicator, 36,000 BTU hot water cab heater, hoist mirrors, engine distress A/V warning system, front/rear tie down and tow lugs, coolant sight level indicator, CraneSTAR asset management system.

*Optional equipment

- **Auxiliary Lighting and Convenience Package:** includes cab mounted amber flashing light, dual base boom mounted floodlights. LMI light bar (in cab), and rubber mat for stowage trough
- 360° NYC style mechanical swing lock
- Rear Pintle hook
- Cab controlled cross axle differential locks, (front and rear)
- PAT event recorder
- 3rd wrap indicator for main and/or auxiliary hoists
- Wind speed indicator (wireless).
- C.E. Mark Conformance
- Value Package: Includes 33 ft - 56 ft manual bi-fold swingaway, 360° swing lock, and auxiliary hoist package
- 29°C/-20°F Cold Weather Package
- 40°C/-40°F Arctic Weather Package
- Spare Tire and Wheel

Dimensions and weights

| Tires | A | B | C | D | E | F | G | A | B | C | D | E | F | G |
|---------------|-------------------|-------------------|-------------------|-------------------|-------------------|-------------------|------------------|-------------------|-------------------|------------------|------------------|------------------|------------------|------------------|
| 29.5 X 25 | 15,7 m (51.5') | 16,3 m (5.35') | 13,6 m (44.6') | 12,9 m (42.3') | 12,5 m (41.0') | 10,1 m (33.1') | 8,8 m (28.9') | 11,1 m (36.4') | 11,6 m (38.1') | 8,4 m (27.6') | 7,8 m (25.6') | 7,3 m (24.0') | 4,9 m (16.1') | 4,1 m (13.5') |
| 2 wheel steer | | | | | | | 4 wheel steer | | | | | | | |

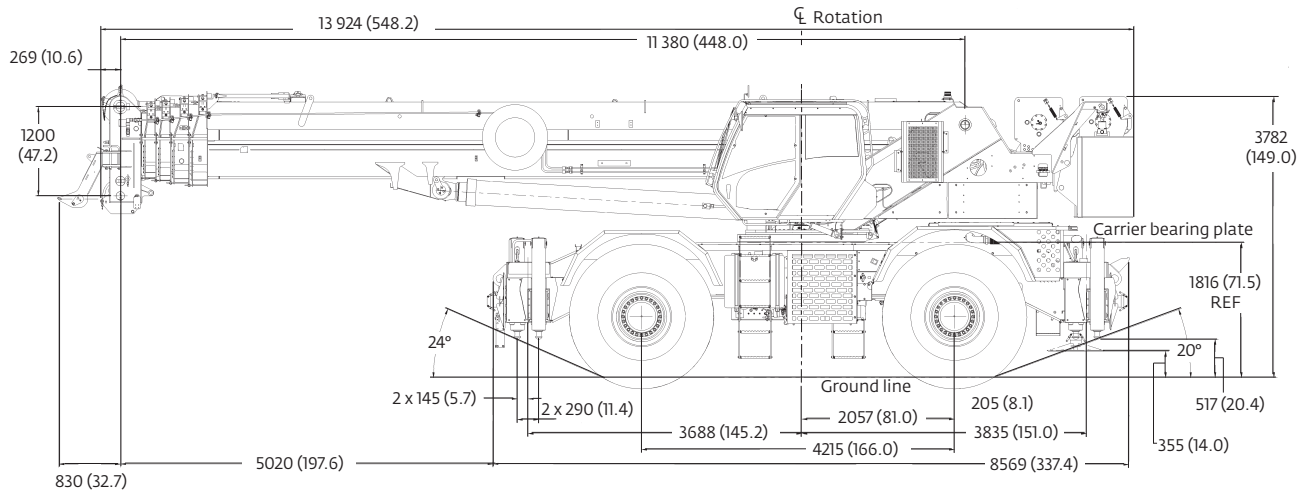
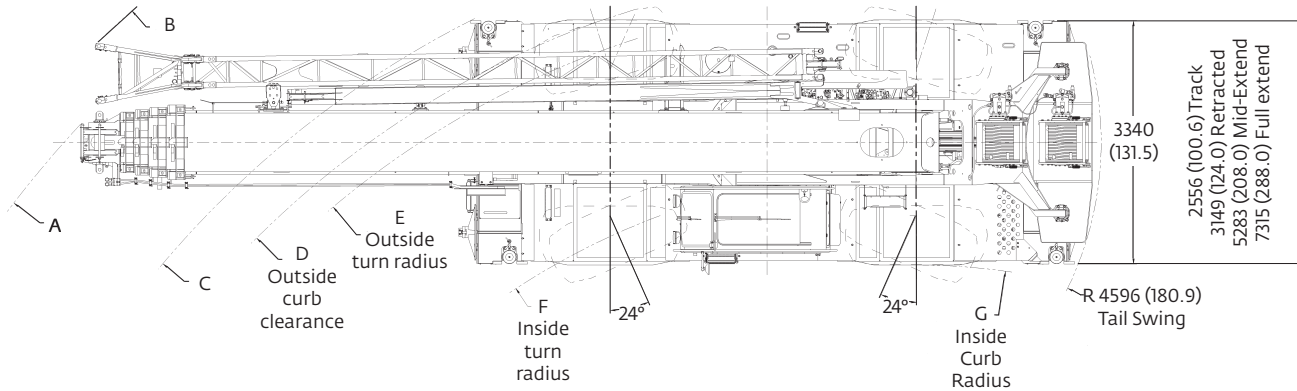

Dimensions are in mm (inches)

| Weights | G.V.W. kg (lb) | Front kg (lb) | Rear kg (lb) |
|--|---------------------|--------------------|--------------------|
| Basic Machine including 43,3 m (142 ft) main boom, main and aux. hoist with 182,8 m (600 ft) of rope, manual offsettable bifold swingaway, full counterweight, 9,1 t (10 USt) headache ball, and 80 t (90 USt) hookblock: | 53 178 (117,235) | 25 915 (57,131) | 27 263 (60,104) |
| Substitute: Hydraulic offsettable bifold swing-away | 53 496 (117,937) | 26 394 (58,187) | 27 103 (59,750) |
| Remove: Counterweight and aux. hoist (manual offsettable S/A) | 43 250 (95,348) | 30 657 (67,587) | 12 592 (27,761) |
| Remove: Counterweight and aux. hoist Hyd. offsettable S/A) | 43 407 (95,695) | 30 930 (68,188) | 12 477 (27,507) |
| Remove: Counterweight, aux. hoist, and either extension | 42 227 (93,094) | 27 696 (64,058) | 13 171 (29,036) |

Working range

141.7 ft main boom 32 ft – 56 ft fixed offset swingaway

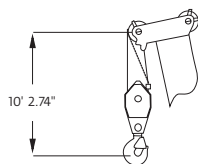
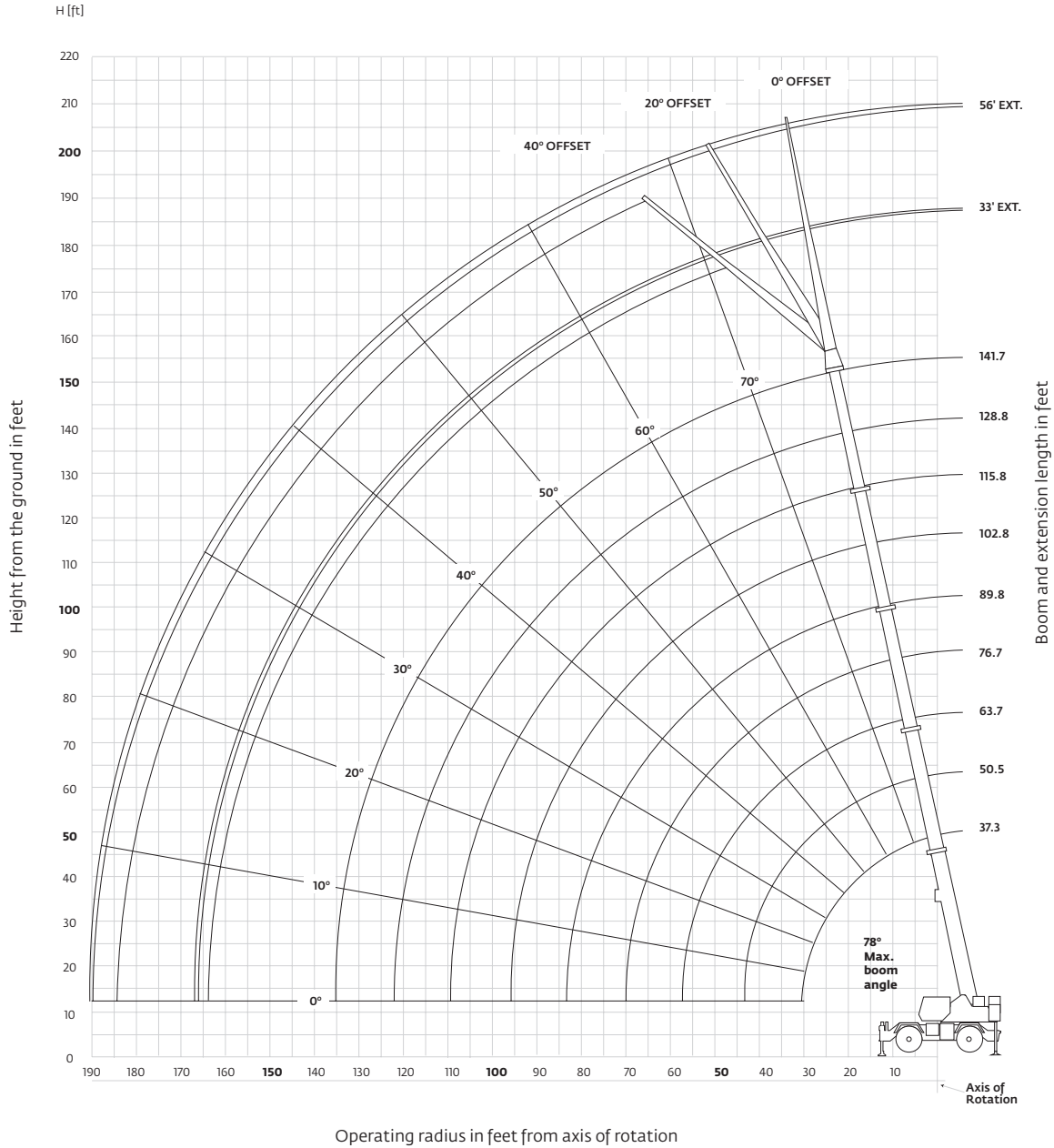

Dimensions are for largest Grove furnished hook block and headache ball, with anti-two block activated.

THIS CHART IS ONLY A GUIDE AND SHOULD NOT BE USED TO OPERATE THE CRANE.

The individual crane's load chart, operating instructions and other instructional plates must be read and understood prior to operating the crane.

Mode A vs. Mode B

| Mode A – inner-mid retracted | | | | | | | | |
|------------------------------|--------------------------|------|------|------|------|-------|-------|-------|
| | Main boom length in feet | | | | | | | |
| | 37.3 | 50.4 | 63.4 | 76.4 | 89.4 | 102.4 | 115.4 | 141.7 |
| Boom sections: | Percent extension | | | | | | | |
| Inner-mid | 0 | 0 | 0 | 0 | 0 | 0 | 0 | 100 |
| Center-mid | 0 | 50 | 100 | 100 | 100 | 100 | 100 | 100 |
| Outer-mid | 0 | 0 | 0 | 25 | 50 | 75 | 100 | 100 |
| Fly | 0 | 0 | 0 | 25 | 50 | 75 | 100 | 100 |

| Mode B – normal mode | | | | | | | | | |
|----------------------|--------------------------|------|------|------|------|-------|-------|-------|-------|
| | Main boom length in feet | | | | | | | | |
| | 37.3 | 50.5 | 63.7 | 76.7 | 89.8 | 102.8 | 115.8 | 128.8 | 141.7 |
| Boom sections: | Percent extension | | | | | | | | |
| Inner-mid | 0 | 50 | 75 | 75 | 100 | 100 | 100 | 100 | 100 |
| Center-mid | 0 | 0 | 25 | 75 | 100 | 100 | 100 | 100 | 100 |
| Outer-mid | 0 | 0 | 0 | 0 | 0 | 25 | 50 | 75 | 100 |
| Fly | 0 | 0 | 0 | 0 | 0 | 25 | 50 | 75 | 100 |

Load charts

(Mode B)





37.3 ft – 141.7 ft **22,000 lb** **100%** **360°**
24 ft spread

| Feet | Main boom length in feet | | | | | | | | |
|------|--------------------------|----------------|---------------|---------------|---------------|---------------|---------------|---------------|---------------|
| | 37.3 | 50.5 | 63.7 | 76.7 | 89.8 | 102.8 | 115.8 | 128.8 | 141.7 |
| 10 | 180,000 (68.5) | 134,000 (75) | *97,500 (78) | | | | | | |
| 12 | 156,000 (65) | 134,000 (72.5) | 97,500 (76.5) | | | | | | |
| 15 | 128,500 (59.5) | 127,500 (69) | 97,500 (74) | 69,950 (77) | *46,600 (78) | | | | |
| 20 | 98,650 (49.5) | 97,600 (62.5) | 86,200 (69) | 63,600 (73) | 46,600 (76.5) | *38,700 (78) | | | |
| 25 | 78,800 (36.5) | 77,800 (55.5) | 74,850 (64) | 55,100 (69) | 41,950 (73) | 38,700 (75.5) | *37,900 (78) | *30,850 (78) | |
| 30 | 51,550 (12.5) | 58,700 (47.5) | 59,300 (58.5) | 48,150 (65) | 37,350 (69.5) | 37,900 (72.5) | 35,000 (75) | 30,850 (77.5) | *24,400 (78) |
| 35 | | 43,250 (38.5) | 43,200 (52.5) | 42,450 (60.5) | 33,300 (66) | 33,200 (69.5) | 30,950 (72.5) | 28,900 (75) | 24,400 (77) |
| 40 | | 33,250 (26) | 32,850 (46.5) | 33,050 (56) | 29,850 (62.5) | 29,300 (66.5) | 27,450 (70) | 25,850 (72.5) | 24,250 (75) |
| 45 | | | 25,650 (39) | 26,000 (51) | 25,900 (58.5) | 25,950 (63.5) | 24,450 (67) | 23,150 (70) | 21,900 (73) |
| 50 | | | 20,350 (30.5) | 20,750 (45.5) | 20,550 (54.5) | 21,950 (60) | 21,800 (64.5) | 20,750 (67.5) | 19,800 (70.5) |
| 55 | | | 16,200 (16.5) | 16,800 (39.5) | 16,450 (50) | 17,800 (56.5) | 19,150 (61.5) | 18,650 (65) | 17,900 (68.5) |
| 60 | | | | 13,600 (33) | 13,200 (45.5) | 14,550 (53) | 15,900 (58.5) | 16,800 (62.5) | 16,150 (66) |
| 65 | | | | 11,000 (23.5) | 10,600 (40.5) | 11,900 (49) | 13,250 (55.5) | 14,200 (60) | 14,650 (64) |
| 70 | | | | | 8420 (34.5) | 9750 (45) | 11,050 (52) | 11,950 (57) | 12,850 (61.5) |
| 75 | | | | | 6570 (28) | 7910 (40.5) | 9250 (48.5) | 10,100 (54.5) | 10,950 (59) |
| 80 | | | | | 4960 (18) | 6340 (36) | 7670 (45) | 8530 (51.5) | 9380 (56.5) |
| 85 | | | | | | 4990 (30) | 6320 (41) | 7150 (48.5) | 7980 (54) |
| 90 | | | | | | 3780 (23) | 5140 (37) | 5950 (45) | 6770 (51) |
| 95 | | | | | | 2710 (10) | 4100 (32) | 4900 (41.5) | 5700 (48.5) |
| 100 | | | | | | | 3160 (26) | 3960 (37.5) | 4750 (45.5) |
| 105 | | | | | | | 2310 (18.5) | 3130 (33.5) | 3910 (42) |
| 110 | | | | | | | | 2370 (28.5) | 3150 (38.5) |
| 115 | | | | | | | | 1680 (22.5) | 2460 (35) |
| 120 | | | | | | | | 1050 (13) | 1840 (30.5) |
| 125 | | | | | | | | | 1250 (25.5) |

Minimum boom angle (deg) for indicated length (no load) 0 24

Maximum boom length (ft) at 0 deg boom angle (no load) 128.8

#LMI operating code. Refer to LMI manual for instructions.

*This capacity is based upon maximum obtainable boom angle.

Note: () Boom angles are in degrees.





| Lifting capacities at zero degree boom angle | | | | | | | | |
|--|--------------------------|---------------|-------------|-------------|-------------|-------------|--------------|--|
| Boom angle | Main boom length in feet | | | | | | | |
| | 37.3 | 50.5 | 63.7 | 76.7 | 89.8 | 102.8 | 115.8 | |
| 0° | 27,500 (30.1) | 15,950 (43.3) | 9560 (56.4) | 5840 (69.5) | 2730 (82.6) | 1910 (95.6) | 1200 (108.5) | |

Note: () Reference radii in feet.

A6-829-103321A

Load charts

Bi-fold swingaway (fixed offsettable angles)

37.3 ft – 141.7 ft **33 ft – 56 ft** **22,000 lb** **100%** **360°**
24 ft spread

| Pounds | | | | | | |
|---|---------------|---------------|--------------|--------------|-------------|-------------|
| Feet | 33 ft LENGTH | | | 56 ft LENGTH | | |
| | 0° OFFSET | 20° OFFSET | 40° OFFSET | 0° OFFSET | 20° OFFSET | 40° OFFSET |
| | #0021 | #0022 | #0023 | #0041 | #0042 | #0043 |
| 40 | 13,700 (78) | | | | | |
| 45 | 13,700 (76.5) | *13,000 (78) | | 7160 (78) | | |
| 50 | 13,700 (75) | 12,950 (77.5) | | 7160 (77.5) | | |
| 55 | 13,700 (73) | 12,600 (76) | *10,250 (78) | 7160 (76) | | |
| 60 | 13,700 (71.5) | 12,200 (74) | 10,050 (77) | 7160 (74.5) | *6400 (78) | |
| 65 | 13,700 (69.5) | 11,900 (72.5) | 9900 (75) | 7160 (73) | 6250 (77.5) | |
| 70 | 13,500 (68) | 11,550 (70.5) | 9750 (73) | 7160 (71.5) | 6110 (76) | |
| 75 | 12,400 (66) | 11,250 (68.5) | 9610 (71) | 7160 (70) | 5980 (74.5) | *5110 (78) |
| 80 | 10,800 (64) | 11,000 (67) | 9480 (69) | 7160 (68.5) | 5850 (73) | 5020 (77) |
| 85 | 9330 (62) | 10,250 (65) | 9370 (67) | 7150 (66.5) | 5730 (71.5) | 4930 (75) |
| 90 | 8050 (60) | 8900 (63) | 8980 (65) | 6960 (65) | 5620 (69.5) | 4850 (73.5) |
| 95 | 6920 (58) | 7700 (61) | 8530 (63) | 6770 (63.5) | 5510 (68) | 4780 (71.5) |
| 100 | 5920 (56) | 6630 (59) | 7360 (61) | 6590 (61.5) | 5410 (66) | 4710 (69.5) |
| 105 | 5030 (54) | 5690 (56.5) | 6310 (58.5) | 6030 (60) | 5310 (64.5) | 4650 (68) |
| 110 | 4230 (52) | 4830 (54.5) | 5370 (56.5) | 5200 (58) | 5220 (62.5) | 4600 (66) |
| 115 | 3510 (49.5) | 4060 (52) | 4520 (54) | 4450 (56.5) | 5110 (60.5) | 4550 (64) |
| 120 | 2850 (47.5) | 3360 (50) | 3750 (51.5) | 3770 (54.5) | 4780 (59) | 4500 (62) |
| 125 | 2250 (45) | 2730 (47.5) | 3040 (49) | 3150 (52.5) | 4080 (57) | 4460 (60) |
| 130 | 1700 (42) | 2150 (44.5) | 2400 (46) | 2580 (50.5) | 3450 (55) | 3970 (58) |
| 135 | 1200 (39.5) | 1610 (42) | | 2060 (48.5) | 2870 (53) | 3330 (55.5) |
| 140 | | 1120 (39) | | 1570 (46.5) | 2330 (50.5) | 2730 (53) |
| 145 | | | | 1130 (44) | 1830 (48.5) | 2180 (50.5) |
| 150 | | | | | 1370 (46) | 1670 (48) |
| 155 | | | | | | 1200 (45) |
| Minimum boom angle (°) for indicated length (no load) | 38 | 38 | 40 | 43 | 44 | 44 |
| Maximum boom length (ft) at 0° boom angle (no load) | | 102.8 | | | 89.8 | |

NOTE: () Boom angles are in degrees.

A6-829-103447

#LMI operating code. Refer to LMI manual for operating instructions.

*This capacity is based upon maximum boom angle.

NOTES:

- All capacities above the bold line are based on structural strength of boom extension and do not exceed 85% of tipping loads, in accordance with SAE J-765.
- The 33 ft extension length may be used with single or double part line lifting service. The 56 ft extension length may be used for single line lifting service only.
- For main boom lengths less than 141.7 ft with the boom extension erected, the rated loads are determined by boom angle. Use only the column which corresponds to the boom extension length and offset for which the machine is set up. For boom angles not shown, use rating of the next lower boom angle.
- WARNING: Operation of this machine with heavier loads than the capacities listed is strictly prohibited. Machine tipping with boom extension occurs rapidly and without advance warning.
- Boom angle is the angle above or below horizontal of the longitudinal axis of the boom base section after lifting rated load.
- Capacities listed are with outriggers properly extended and vertical jacks set only.
- When lifting over the main boom nose with 33 ft or 56 ft extension erected, the outriggers must be fully extended or 50% extended (17.3 ft spread).

THIS CHART IS ONLY A GUIDE AND SHOULD NOT BE USED TO OPERATE THE CRANE.

Working range

141.7 ft main boom and one 16 ft insert

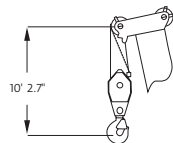
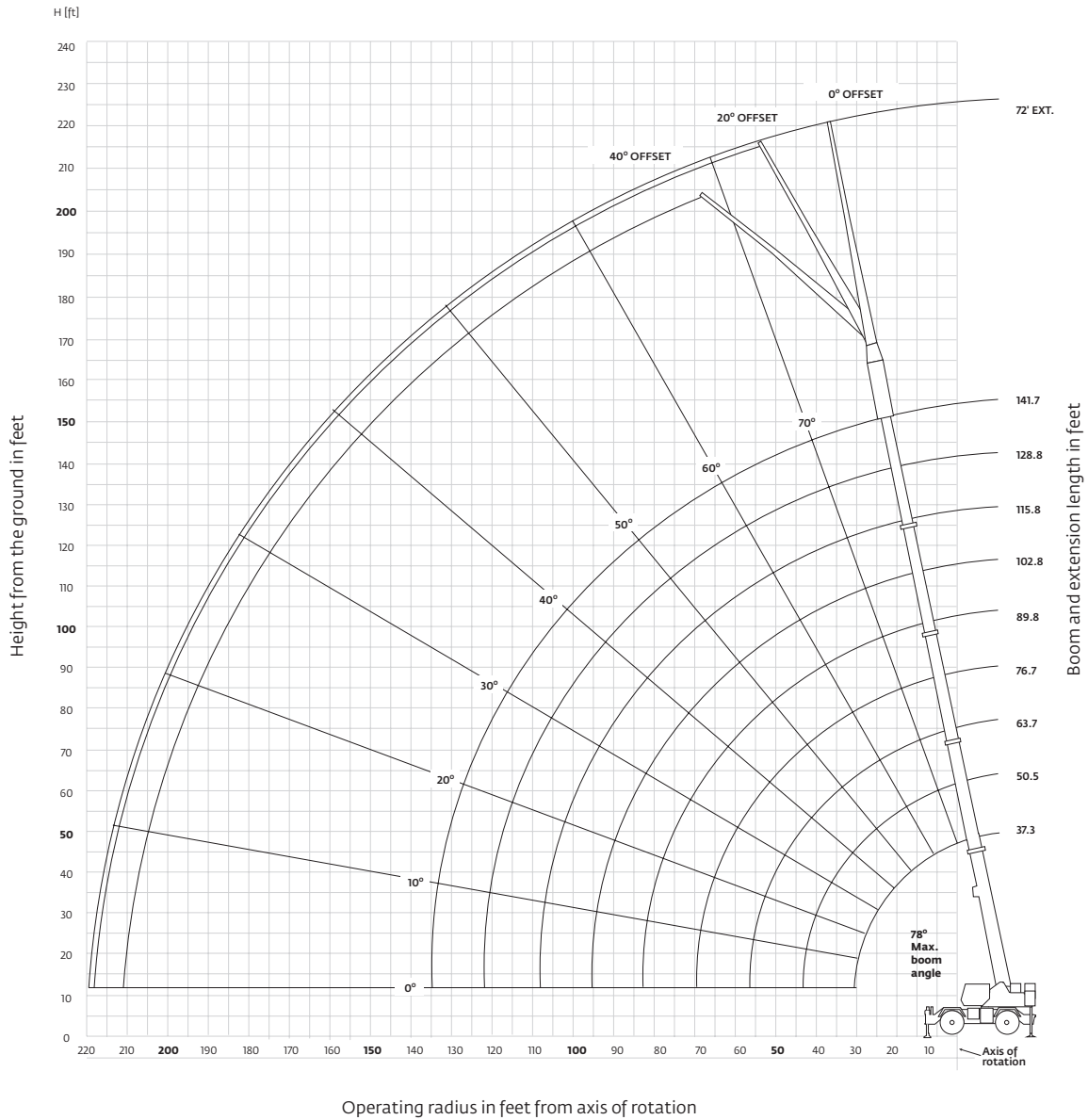

Dimensions are for largest Grove furnished hook block and headache ball, with anti-two block activated.

Working range

141.7 ft main boom and two 16 ft inserts

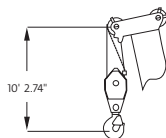
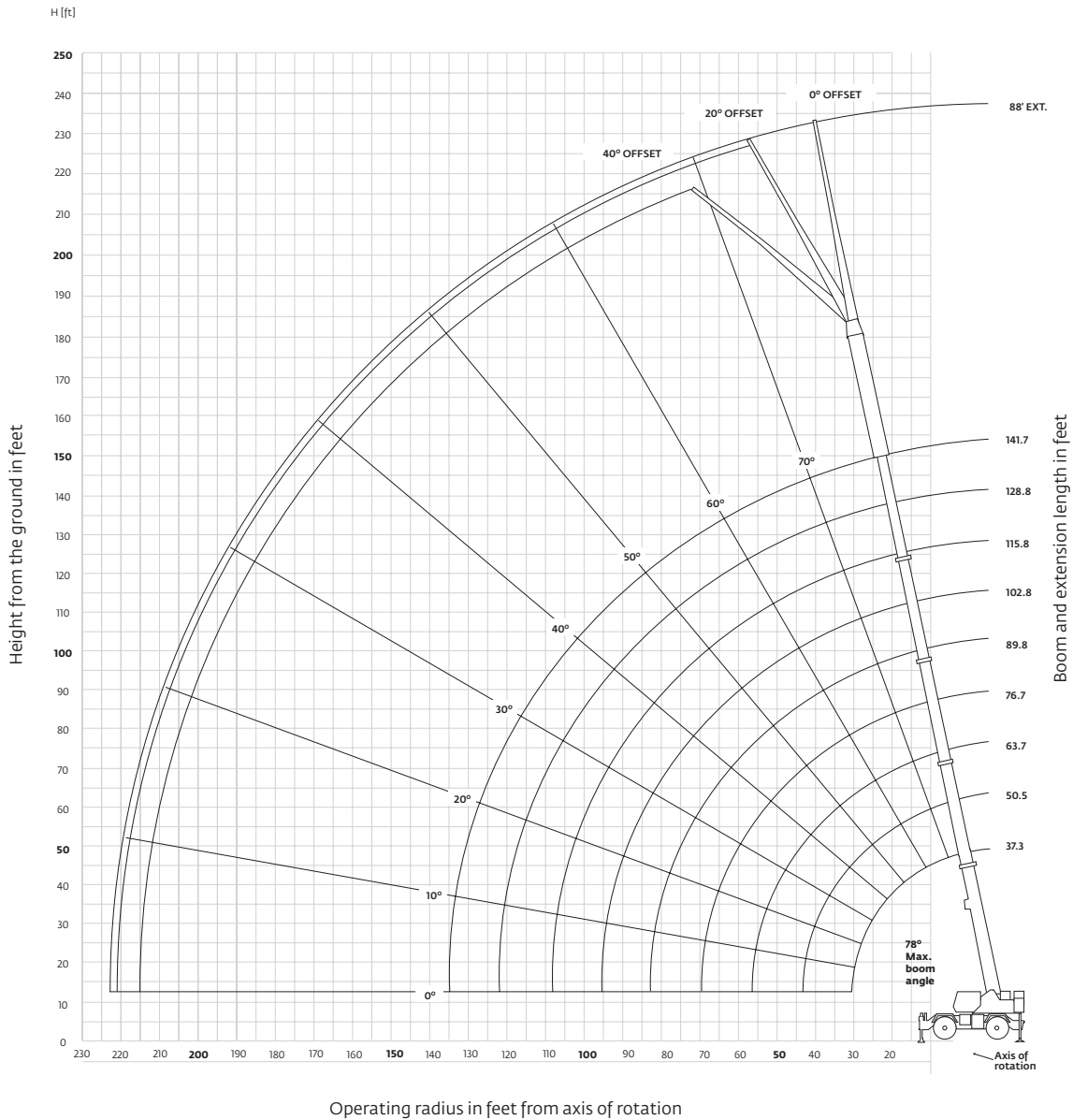

Dimensions are for largest Grove furnished hook block and headache ball, with anti-two block activated.

Load charts

Bi-fold swingaway with inserts (fixed angles)

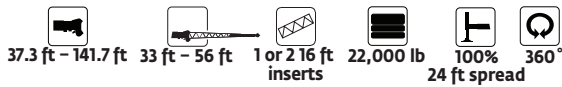

| Pounds | | | | | | |
|---|---------------------------------|----------------|----------------|----------------------------------|----------------|----------------|
| Feet | 72 ft (56 ft LENGTH + 1 INSERT) | | | 88 ft (56 ft LENGTH + 2 INSERTS) | | |
| | 0° | 20° | 40° | 0° | 20° | 40° |
| | OFFSET | OFFSET | OFFSET | OFFSET | OFFSET | OFFSET |
| | #0064 | #0065 | #0066 | #0084 | #0085 | #0086 |
| 50 | 6300 (78) | | | | | |
| 55 | 6300 (77.5) | | | | | |
| 60 | 6300 (76.5) | | | 5000 (78) | | |
| 65 | 6300 (75) | | | 5000 (77.5) | | |
| 70 | 6300 (73.5) | *6100 (78) | | 5000 (76) | | |
| 75 | 6,00 (72) | 5860 (77.5) | | 5000 (74.5) | *4900 (78) | |
| 80 | 6300 (70.5) | 5750 (76) | *5000 (78) | 5000 (73.5) | 4900 (77.5) | |
| 85 | 6300 (69) | 5650 (74.5) | 4890 (77.5) | 5000 (72) | 4900 (76) | |
| 90 | 6300 (67.5) | 5550 (73) | 4820 (76) | 4900 (70.5) | 4900 (74.5) | *4800 (78) |
| 95 | 6300 (66) | 5450 (71.5) | 4760 (74.5) | 4850 (69.5) | 4900 (73.5) | 4640 (76.5) |
| 100 | 6300 (64.5) | 5360 (70) | 4690 (73) | 4800 (68) | 4710 (72) | 4370 (75) |
| 105 | 5810 (63) | 5120 (68) | 4580 (71.5) | 4670 (66.5) | 4420 (70.5) | 4120 (73.5) |
| 110 | 5030 (61.5) | 4880 (66.5) | 4480 (69.5) | 4550 (65) | 4130 (69) | 3870 (72) |
| 115 | 4320 (59.5) | 4620 (65) | 4270 (68) | 4240 (63.5) | 3880 (67.5) | 3650 (70.5) |
| 120 | 3680 (58) | 4370 (63.5) | 4060 (66) | 3850 (62) | 3630 (66) | 3440 (69) |
| 125 | 3100 (56.5) | 4110 (61.5) | 3870 (64.5) | 3260 (60.5) | 3410 (64.5) | 3240 (67.5) |
| 130 | 2560 (54.5) | 3500 (60) | 3680 (62.5) | 2720 (59) | 3190 (63) | 3050 (65.5) |
| 135 | 2070 (53) | 2940 (58) | 3510 (60.5) | 2220 (57.5) | 3000 (61.5) | 2880 (64) |
| 140 | 1610 (51) | 2420 (56) | 2980 (58.5) | 1760 (56) | 2630 (60) | 2710 (62.5) |
| 145 | 1190 (49) | 1950 (54.5) | 2440 (56.5) | 1340 (54.5) | 2,150 (58) | 2560 (60.5) |
| 150 | | 1500 (52.5) | 1930 (54.5) | | 1700 (56.5) | 2210 (58.5) |
| 155 | | 1090 (50.5) | 1470 (52) | | 1290 (54.5) | 1750 (57) |
| 160 | | | 1030 (50) | | | 1310 (55) |
| Minimum boom angle (°) for indicated length (no load) | 48 | 49 | 49 | 52 | | 53 |
| Maximum boom length (ft) at 0° boom angle (no load) | | 76.7 | | | 76.7 | |

NOTE: () Boom angles are in degrees. A6-829-103478
 #LMI operating code. Refer to LMI manual for operating instructions.
 *This capacity is based upon maximum boom angle.

NOTES:

1. All capacities above the bold line are based on structural strength of boom extension and do not exceed 85% of tipping loads, in accordance with SAE J-765.
2. The 56 ft extension length may be used for single line lifting service only.
3. For main boom lengths less than 141.7 ft with the boom extension erected, the rated loads are determined by boom angle. Use only the column which corresponds to the boom extension length and offset for which the machine is set up. For boom angles not shown, use rating of the next lower boom angle.
4. WARNING: Operation of this machine with heavier loads than the capacities listed is strictly prohibited. Machine tipping with boom extension occurs rapidly and without advance warning.
5. Boom angle is the angle above or below horizontal of the longitudinal axis of the boom base section after lifting rated load.
6. When lifting over the main boom nose with 56 ft extension erected and inserts, the outriggers must be fully extended and vertical jacks set.

Load charts

(Mode A)





37.3 ft – 141.7 ft **22,000 lb** **100%** **360°**
24 ft spread

| Feet | 37.3 | 50.4 | 63.4 | 76.4 | 89.4 | 102.4 | 115.4 | 141.7 |
|------|-------------------|-------------------|------------------|------------------|------------------|------------------|------------------|------------------|
| 10 | 180,000 (68.5) | 134,000 (75) | *80,800 (78) | | | | | |
| 12 | 156,000 (65) | 134,000 (72.5) | 80,800 (76.5) | *38,700 (78) | | | | |
| 15 | 128,500 (59.5) | 129,000 (68.5) | 80,800 (73.5) | 38,700 (77) | *38,500 (78) | | | |
| 20 | 98,650 (49.5) | 98,950 (62) | 70,950 (68.5) | 38,700 (73) | 38,500 (76.5) | *38,400 (78) | | |
| 25 | 78,800 (36.5) | 79,150 (55) | 62,300 (63.5) | 38,700 (69) | 38,500 (73) | 38,400 (76) | 24,400 (78) | |
| 30 | 51,550 (12.5) | 60,500 (47) | 55,250 (58) | 38,700 (65) | 38,500 (69.5) | 37,500 (73) | 24,400 (76) | *24,400 (78) |
| 35 | | 45,150 (38) | 44,900 (52.5) | 38,700 (60.5) | 36,750 (66) | 33,150 (70) | 24,400 (73.5) | 24,400 (77) |
| 40 | | 35,250 (25.5) | 34,700 (46) | 36,750 (56) | 32,750 (62) | 29,550 (67) | 24,400 (70.5) | 24,250 (75) |
| 45 | | | 27,600 (39) | 29,450 (51) | 29,400 (58.5) | 26,500 (63.5) | 24,400 (68) | 21,900 (73) |
| 50 | | | 22,400 (30) | 24,000 (45.5) | 25,650 (54.5) | 23,950 (60.5) | 22,050 (65) | 19,800 (70.5) |
| 55 | | | 18,250 (15.5) | 19,850 (39.5) | 21,350 (50) | 21,750 (57) | 20,000 (62) | 17,900 (68.5) |
| 60 | | | | 16,600 (32.5) | 17,950 (45.5) | 18,900 (53.5) | 18,250 (59) | 16,150 (66) |
| 65 | | | | 13,850 (23) | 15,200 (40) | 16,150 (49.5) | 16,700 (56) | 14,650 (64) |
| 70 | | | | | 12,950 (34.5) | 13,850 (45.5) | 14,800 (53) | 12,850 (61.5) |
| 75 | | | | | 11,000 (27.5) | 11,950 (41) | 12,900 (49.5) | 10,950 (59) |
| 80 | | | | | 9340 (17) | 10,300 (36) | 11,250 (45.5) | 9380 (56.5) |
| 85 | | | | | | 8900 (30) | 9830 (42) | 7980 (54) |
| 90 | | | | | | 7640 (22.5) | 8590 (37.5) | 6770 (51) |
| 95 | | | | | | 6520 (8) | 7510 (32.5) | 5700 (48.5) |
| 100 | | | | | | | 6520 (26.5) | 4750 (45.5) |
| 105 | | | | | | | | 5640 (18.5) |
| 110 | | | | | | | | 3150 (38.5) |
| 115 | | | | | | | | 2460 (35) |
| 120 | | | | | | | | 1840 (30.5) |
| 125 | | | | | | | | 1250 (25.5) |
| | | | | | | | | 24 |
| | | | | | | | | 115.4 |

Minimum boom angle (deg) for indicated length (no load)

Maximum boom length (ft) at 0 deg boom angle (no load)

#LMI operating code. Refer to LMI manual for instructions.

*This capacity is based upon maximum obtainable boom angle.

Note: () Boom angles are in degrees.

| Lifting capacities at zero degree boom angle | | | | | | | | |
|--|--------------------------|------------------|------------------|----------------|----------------|----------------|-----------------|--|
| Boom angle | Main boom length in feet | | | | | | | |
| | 37.3 | 50.4 | 63.4 | 76.4 | 89.4 | 102.4 | 115.4 | |
| 0° | 27,500 (30.1) | 17,300 (43.2) | 11,050 (56.2) | 8580 (69.2) | 6700 (82.2) | 5380 (95.2) | 4280 (108.2) | |

Note: () Reference radii in feet.

6-829-103320A

THIS CHART IS ONLY A GUIDE AND SHOULD NOT BE USED TO OPERATE THE CRANE.

Load charts

(Mode A)





Pounds

Main boom

| Feet | Main boom length in feet | | | |
|---|--------------------------|------------------|------------------|----------------|
| | 37.3 | 50.4 | 63.4 | 76.4 |
| 12 | 39,500 (65) | 41,650 (72.5) | | |
| 15 | 37,750 (59.5) | 38,950 (68.5) | 18,900 (73.5) | 15,650 (77) |
| 20 | 24,850 (49.5) | 24,850 (62) | 18,900 (68.5) | 15,650 (73) |
| 25 | 16,300 (36.5) | 16,650 (55) | 17,450 (63.5) | 15,650 (69) |
| 30 | 10,200 (12.5) | 11,350 (47) | 11,450 (58) | 13,200 (65) |
| 35 | | 7650 (38) | 7630 (52.5) | 9280 (60.5) |
| 40 | | 4920 (25.5) | 5020 (46) | 6510 (56) |
| 45 | | | | 4490 (51) |
| Minimum boom angle (°) for indicated length (no load) | | | 39 | 46 |
| Maximum boom length (ft) at 0° boom angle (no load) | | | 50.4 | |
| Lifting capacities at zero degree boom angle | | | | |
| Boom angle | Main boom length in feet | | | |
| | 37.3 | 50.4 | | |
| 0° | 10,050 (30.1) | 3150 (43.2) | | |

NOTE: () Reference radii in feet. A6-829-103452A
#LMI operating code. Refer to LMI manual for instructions.





Pounds

Main boom

| Feet | Main boom length in feet | | | |
|---|--------------------------|------------------|------------------|------------------|
| | 37.3 | 50.4 | 63.4 | 76.4 |
| 12 | 41,600 (65) | 41,700 (72.5) | | |
| 15 | 41,600 (59.5) | 41,700 (68.5) | 22,400 (73.5) | 15,650 (77) |
| 20 | 36,250 (49.5) | 36,450 (62) | 22,400 (68.5) | 15,650 (73) |
| 25 | 27,600 (36.5) | 28,250 (55) | 22,400 (63.5) | 15,650 (69) |
| 30 | 21,300 (12.5) | 22,200 (47) | 22,400 (58) | 15,650 (65) |
| 35 | | 17,500 (38) | 17,950 (52.5) | 15,650 (60.5) |
| 40 | | 13,800 (25.5) | 14,350 (46) | 15,650 (56) |
| 45 | | | 11,000 (39) | 12,500 (51) |
| 50 | | | 8360 (30) | 9820 (45.5) |
| 55 | | | 6240 (15.5) | 7690 (39.5) |
| Minimum boom angle (°) for indicated length (no load) | | | 36 | |
| Maximum boom length (ft) at 0° boom angle (no load) | | | 63.4 | |
| Lifting capacities at zero degree boom angle | | | | |
| Boom angle | Main boom length in feet | | | |
| | 37.3 | 50.4 | 63.4 | |
| 0° | 21,150 (30.1) | 11,600 (43.2) | 5790 (56.2) | |

A6-829-103453
#LMI operating code. Refer to LMI manual for instructions.

NOTES:

- Capacities are in pounds and do not exceed 75% of tipping loads as determined by test in accordance with SAE J765.
- Capacities are applicable to machines equipped with 29.5x25 (34 ply) General tires at 76 psi cold inflation pressure.
- Capacities appearing above the bold line are based on structural strength and tipping should not be relied upon as a capacity limitation.
- Capacities are applicable only with machine on firm level surface.
- On rubber lifting with boom extensions not permitted.
- For pick and carry operation, boom must be centered over front of machine, mechanical swing lock engaged and load restrained from swinging. When handling loads in the structural range with capacities close to maximum ratings, travel should be reduced to creep speeds.
- Axle lockouts must be functioning when lifting on rubber.
- All lifting depends on proper tire inflation, capacity and condition. Capacities must be reduced for lower tire inflation pressures. See lifting capacity chart for tire used. Damaged tires are hazardous to safe operation of crane.
- Creep – not over 200 ft of movement in any 30 minute period and not exceeding 1 mph.

THIS CHART IS ONLY A GUIDE AND SHOULD NOT BE USED TO OPERATE THE CRANE.

The individual crane's load chart, operating instructions and other instructional plates must be read and understood prior to operating the crane.

33 ft – 56 ft luffing bi-fold boom extension (Mode B) (fixed offsettable angles)



| Pounds | | | | | | |
|---|-----------------------------|------------------------|-----------------------------|---------------------------|------------------------|------------------------|
| Feet | 33 ft LENGTH | | | 56 ft LENGTH | | |
| | 5° OFFSET #0091 | 20° OFFSET #0091 | 40° OFFSET #0091 | 5° OFFSET #0092 | 20° OFFSET #0092 | 40° OFFSET #0092 |
| 40 | [*] 13,700 (78) | | | | | |
| 45 | 13,700 (77) | | | | | |
| 50 | 13,700 (75) | 13,700 (77.5) | | [*] 8200 (78) | | |
| 55 | 13,700 (73.5) | 13,700 (75.5) | [*] 11,000 (78) | 8200 (77.5) | | |
| 60 | 13,700 (71.5) | 13,700 (74) | 11,000 (76) | 8200 (76) | | |
| 65 | 13,700 (70) | 12,850 (72) | 10,950 (74.5) | 8200 (74.5) | 8200 (77.5) | |
| 70 | 12,500 (68) | 12,000 (70) | 10,350 (72.5) | 8200 (73) | 8200 (76) | |
| 75 | 11,350 (66) | 11,200 (68) | 9830 (70.5) | 8200 (71.5) | 8100 (74) | 6400 (77.5) |
| 80 | 9730 (64.5) | 10,450 (66.5) | 9330 (68.5) | 8200 (69.5) | 7600 (72.5) | 6400 (76) |
| 85 | 8300 (62.5) | 8980 (64.5) | 8860 (66.5) | 8200 (68) | 7150 (71) | 6230 (74) |
| 90 | 7060 (60.5) | 7660 (62.5) | 8210 (64.5) | 7740 (66.5) | 6730 (69) | 5920 (72.5) |
| 95 | 5960 (58.5) | 6500 (60.5) | 6980 (62) | 7130 (64.5) | 6350 (67.5) | 5640 (70.5) |
| 100 | 4990 (56.5) | 5470 (58) | 5880 (60) | 6130 (63) | 6000 (65.5) | 5380 (68.5) |
| 105 | 4120 (54) | 4560 (56) | 4900 (58) | 5230 (61) | 5690 (64) | 5140 (67) |
| 110 | 3340 (52) | 3730 (54) | 4020 (55.5) | 4430 (59.5) | 5290 (62) | 4900 (65) |
| 115 | 2640 (49.5) | 2990 (51.5) | 3230 (53) | 3700 (57.5) | 4490 (60) | 4690 (63) |
| 120 | 2000 (47.5) | 2320 (49) | 2510 (50.5) | 3040 (55.5) | 3760 (58.5) | 4470 (61) |
| 125 | 1420 (45) | 1700 (46.5) | 1850 (47.5) | 2440 (53.5) | 3100 (56.5) | 3710 (58.5) |
| 130 | | 1140 (44) | 1250 (45) | 1900 (51.5) | 2500 (54.5) | 3030 (56.5) |
| 135 | | | | 1390 (49.5) | 1940 (52) | 2390 (54) |
| 140 | | | | | 1420 (50) | 1810 (52) |
| 145 | | | | | | 1270 (49) |
| Minimum boom angle (°) for indicated length (no load) | 42 | 43 | 43 | 48 | 48 | 47 |
| Maximum boom length (ft) at 0° boom angle (no load) | | 89.8 | | | 76.7 | |

NOTE: () Boom angles are in degrees. A6-829-103522
#LMI operating code. Refer to LMI manual for operating instructions.
*This capacity is based upon maximum boom angle.

NOTES:

- All capacities above the bold line are based on structural strength of boom extension and do not exceed 85% of tipping loads, in accordance with SAE J-765.
- The 33 ft luffing folding boom extension may be used for single or double line lifting service. The 56 ft luffing folding boom extension may be used for single line lifting service only. WARNING: Lifting with the 33 ft extension base, with the 23 ft extension fly either erected or folded along side of extension base, is strictly prohibited.
- WARNING: Operation of this machine with heavier loads than the capacities listed is strictly prohibited. Machine tipping with boom extension occurs rapidly and without advance warning.
- Boom angle is the angle above or below horizontal of the longitudinal axis of the boom base section after lifting rated load.
- Capacities listed are with outriggers properly extended and vertical jacks set only.
- For main boom lengths less than 141.7 ft with the boom extension erected, the rated loads are determined by boom angle. Use only the column which corresponds to the boom extension length and offset for which the machine is set up. For boom angles not shown, use rating of the next lower boom angle.
- When lifting over the main boom nose with 33 ft or 56 ft extension erected, the outriggers must be fully extended or 50% extended (17.3 ft spread).

THIS CHART IS ONLY A GUIDE AND SHOULD NOT BE USED TO OPERATE THE CRANE.

33 ft – 56 ft luffing bi-fold boom extension (Mode B) (intermediate offsettable angles)

 37.3 ft – 141.7 ft
  33 ft – 56 ft
  22,000 lb
  100%
24 ft spread
  360°

| Pounds | | | | |
|--|--------------------------|------------------|-----------------|---------------------------|
| Feet | 33 ft LENGTH | | 56 ft LENGTH | |
| | 5° - 20° OFFSET #0091 | 20° - 40° OFFSET | 5° - 20° OFFSET | 20° - 40° OFFSET #0092 |
| 50 | 11,850 | | | |
| 55 | 11,550 | 10,750 | | |
| 60 | 11,200 | 10,600 | | |
| 65 | 10,900 | 10,450 | 6150 | |
| 70 | 10,650 | 10,350 | 5960 | |
| 75 | 10,350 | 9830 | 5780 | 5370 |
| 80 | 9730 | 9330 | 5610 | 5280 |
| 85 | 8300 | 8860 | 5450 | 5200 |
| 90 | 7060 | 7660 | 5310 | 5130 |
| 95 | 5960 | 6500 | 5170 | 5070 |
| 100 | 4990 | 5470 | 5040 | 5010 |
| 105 | 4120 | 4560 | 4920 | 4910 |
| 110 | 3340 | 3730 | 4430 | 4810 |
| 115 | 2640 | 2990 | 3700 | 4490 |
| 120 | 2000 | 2320 | 3040 | 3760 |
| 125 | 1420 | 1700 | 2440 | 3100 |
| 130 | | 1140 | 1900 | 2500 |
| 135 | | | 1390 | 1940 |
| 140 | | | | 1420 |
| Min. boom angle for indicated length (no load) | 43° | 43° | 48° | 48° |
| Max. boom length at 5° boom angle (no load) | 89.8' | | 76.7' | |

#LMI operating code. Refer to LMI manual for operating instructions. A6-829-103525A

NOTES:

1. All capacities above the bold line are based on structural strength of boom extension and do not exceed 85% of tipping loads, in accordance with SAE J-765.
2. The 33 ft luffing folding boom extension may be used for single or double line lifting service. The 56 ft luffing folding boom extension may be used for single line lifting service only.
WARNING: Lifting with the 33 ft extension fly either erected or folded along side of extension base, is strictly prohibited.
3. WARNING: Operation of this machine with heavier loads than the capacities listed is strictly prohibited. Machine tipping with boom extension occurs rapidly and without advance warning.
4. The loads for luffing depend on the angle of the main boom, angle of the boom extension and dynamic working pressure of the luffing cylinder for the boom extension.
5. Capacities listed are with outriggers properly extended and vertical jacks set only.
6. When lifting over the main boom nose with 33 ft or 56 ft extension erected, the outriggers must be fully extended or 50% extended (17.3 ft spread).

33 ft – 56 ft luffing bifold boom extension with inserts (Mode B) (intermediate offsettable angles)

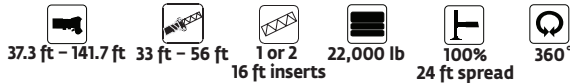

| Pounds | | | | | | |
|---|---------------------------------|------------------------|------------------------|----------------------------------|------------------------|------------------------|
| Feet | 72 ft (56 ft LENGTH + 1 INSERT) | | | 88 ft (56 ft LENGTH + 2 INSERTS) | | |
| | 5° OFFSET #0095 | 20° OFFSET #0095 | 40° OFFSET #0095 | 5° OFFSET #1095 | 20° OFFSET #1095 | 40° OFFSET #1095 |
| 55 | *6400 (78) | | | | | |
| 60 | 6400 (77.5) | | | | | |
| 65 | 6400 (76) | | | *5000 (78) | | |
| 70 | 6400 (74.5) | *6400 (78) | | 5000 (77) | | |
| 75 | 6400 (73.5) | 6400 (76.5) | | 5000 (75.5) | *5000 (78) | |
| 80 | 6400 (72) | 6400 (75) | *5500 (78) | 5000 (74.5) | 5000 (76) | |
| 85 | 6400 (70.5) | 6040 (73.5) | 5420 (76) | 5000 (73) | 5000 (74.5) | *4460 (78) |
| 90 | 6250 (69) | 5630 (72) | 5100 (74.5) | 5000 (71.5) | 4790 (73) | 4460 (76.5) |
| 95 | 5800 (67.5) | 5260 (70.5) | 4800 (73) | 4740 (70) | 4420 (71.5) | 4150 (75) |
| 100 | 5380 (66) | 4910 (69) | 4520 (71.5) | 4350 (69) | 4090 (70.5) | 3860 (73.5) |
| 105 | 5010 (64) | 4610 (67.5) | 4270 (69.5) | 4010 (67.5) | 3790 (69) | 3600 (72) |
| 110 | 4570 (62.5) | 4310 (65.5) | 4020 (68) | 3680 (66) | 3490 (67.5) | 3340 (70.5) |
| 115 | 3840 (61) | 4040 (64) | 3790 (66) | 3390 (64.5) | 3230 (66) | 3110 (69) |
| 120 | 3180 (59.5) | 3780 (62.5) | 3570 (64.5) | 3110 (63) | 2980 (64.5) | 2890 (67.5) |
| 125 | 2570 (57.5) | 3290 (60.5) | 3370 (62.5) | 2720 (61.5) | 2760 (63) | 2680 (66) |
| 130 | 2020 (56) | 2680 (59) | 3180 (60.5) | 2160 (60) | 2540 (61.5) | 2480 (64.5) |
| 135 | 1510 (54) | 2120 (57) | 2680 (59) | 1640 (58.5) | 2300 (59.5) | 2300 (62.5) |
| 140 | 1040 (52.5) | 1600 (55) | 2100 (57) | 1170 (57) | 1780 (58) | 2120 (61) |
| 145 | | 1130 (53) | 1560 (54.5) | | 1300 (56.5) | 1820 (59) |
| 150 | | | 1060 (52.5) | | | 1320 (57) |
| Minimum boom angle (°) for indicated length (no load) | 51 | 52 | 51 | 56 | 55 | 56 |
| Maximum boom length (ft) at 0° boom angle (no load) | | 76.7 | | | 63.7 | |

NOTE: () Boom angles are in degrees. A6-829-103523

#LMI operating code. Refer to LMI manual for operating instructions.







*This capacity is based upon maximum boom angle.

NOTES:

1. All capacities above the bold line are based on structural strength of boom extension and do not exceed 85% of tipping loads, in accordance with SAE J-765.
2. The 56 ft luffing folding boom extension may be used for single line lifting service only.
3. WARNING: Operation of this machine with heavier loads than the capacities listed is strictly prohibited. Machine tipping with boom extension occurs rapidly and without advance warning.
4. WARNING: Lifting with the 33 ft extension base, with the 23 ft extension fly either erected or folded along side of extension base, or with either one or two 16 ft insert sections installed, is strictly prohibited.
5. For main boom lengths less than 141.7 ft with the boom extension erected, the rated loads are determined by boom angle. Use only the column which corresponds to the boom extension length and offset for which the machine is set up. For boom angles not shown, use rating of the next lower boom angle.
6. When lifting over the main boom nose with the 56 ft extension erected and inserts, the outriggers must be fully extended and vertical jacks set.

THIS CHART IS ONLY A GUIDE AND SHOULD NOT BE USED TO OPERATE THE CRANE.

33 ft – 56 ft luffing bi-fold boom extension with inserts (Mode B) (intermediate offsettable angles)

 37.3 ft – 141.7 ft
  33 ft – 56 ft
  1 or 2
16 ft inserts
  22,000 lb
  100%
24 ft spread
  360°

| Feet | Pounds | | | |
|--|---------------------------------|---------------------|----------------------------------|---------------------|
| | 72 ft LENGTH (56 ft + 1 INSERT) | | 88 ft LENGTH (56 ft + 2 INSERTS) | |
| | 5° - 20° OFFSET | 20° - 40° OFFSET | 5° - 20° | 20° - 40° OFFSET |
| | #0095 | | #1095 | |
| 70 | 6090 | | | |
| 75 | 5920 | | 5000 | |
| 80 | 5750 | 5340 | 5000 | |
| 85 | 5600 | 5260 | 5000 | 4460 |
| 90 | 5460 | 5100 | 4790 | 4460 |
| 95 | 5260 | 4800 | 4420 | 4150 |
| 100 | 4910 | 4520 | 4090 | 3860 |
| 105 | 4610 | 4270 | 3790 | 3600 |
| 110 | 4310 | 4020 | 3490 | 3340 |
| 115 | 3840 | 3790 | 3230 | 3110 |
| 120 | 3180 | 3570 | 2980 | 2890 |
| 125 | 2570 | 3290 | 2720 | 2680 |
| 130 | 2020 | 2680 | 2160 | 2480 |
| 135 | 1510 | 2120 | 1640 | 2300 |
| 140 | 1040 | 1600 | 1170 | 1780 |
| 145 | | 1130 | | 1300 |
| Min. boom angle for indicated length (no load) | 52° | 52° | 56° | 56° |
| Max. boom length at 5° boom angle (no load) | 76.7 | | 63.7 | |

AG-829-103526

#LMI operating code. Refer to LMI manual for operating instructions.

NOTES:

1. All capacities above the bold line are based on structural strength of boom extension and do not exceed 85% of tipping loads, in accordance with SAE J-765.
2. The 56 ft luffing folding boom extension may be used for single line lifting service only
WARNING: Lifting with the 33 ft extension base, with the 23 ft extension fly either erected or folded along side of extension base, or with either one or two 16 ft insert sections installed, is strictly prohibited.
3. WARNING: Operation of this machine with heavier loads than the capacities listed is strictly prohibited. Machine tipping with boom extension occurs rapidly and without advance warning.
4. The loads for luffing depend on the angle of the main boom, angle of the boom extension and dynamic working pressure of the luffing cylinder for the boom extension.
5. When lifting over the main boom nose with 56 ft extension erected and inserts, the outriggers must be fully extended and vertical jacks set only.

Load handling

Weight reductions for load handling devices

33 ft - 56 ft Folding boom extension

| | |
|----------------------------|-----------|
| *33 ft extension (erected) | 3750 lb |
| *56 ft extension (erected) | 8000 lb |
| *72 ft (1 insert erected) | 10,450 lb |
| *88 ft (2 inserts erected) | 13,000 lb |

*Reduction of main boom capacities
(no deduct required for stowed boom extension)

| | |
|--------------------------------|-----------|
| Auxiliary boom nose | 133 lb |
| Hookblocks and headache balls: | |
| 80 USt, 5 sheave | 1600 lb + |
| 90 USt, 5 sheave | 1300 lb + |
| 10 USt overhaul ball | 568 lb + |

+ Refer to rating plate for actual weight.

When lifting over swingaway and/or jib combinations, deduct total weight of all load handling devices reeved over main boom nose directly from swingaway or jib capacity.

NOTE: All load handling devices and boom attachments are considered part of the load and suitable allowances **MUST BE MADE** for their combined weights. Weights are for Grove furnished equipment.

Line pulls and reeving information

| Hoists | Cable specs | Permissible line pulls | Nominal cable length |
|--------|-------------|------------------------|----------------------|
|--------|-------------|------------------------|----------------------|

| | | | |
|------|---|-----------|--------|
| Main | 19 mm (3/4 in) 6x37 class, EIPS, IWRC special flexible min. breaking str. 58,800 lb | 16,800 lb | 600 ft |
|------|---|-----------|--------|

| | | | |
|---------------|---|-----------|--------|
| Main and Aux. | 19 mm (3/4 in) Flex-X 35 rotation resistant (non-rotating) min. breaking strength 85,800 lb | 16,800 lb | 600 ft |
|---------------|---|-----------|--------|

The approximate weight of 3/4 in wire rope is 1.5 lb/ft

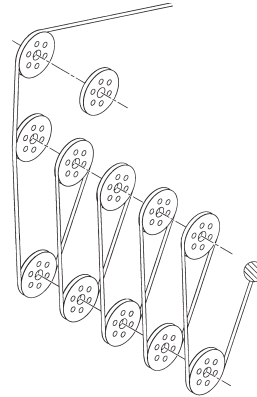

Installation and removal of counterweight and auxiliary hoist

Rated lifting capacities in pounds on outriggers fully extended -

| Radius in feet | LMI Code #0801 Main boom length |
|----------------|------------------------------------|
| | 37.3 ft* |
| 10 | 24,000 |
| 12 | 24,000 |
| 15 | 24,000 |
| 20 | 24,000 |
| 25 | 24,000 |
| 30 | 24,000 |

*The boom must be fully retracted.

A6-829-103450

Hoist performance

| Wire rope layer | Hoist line pulls two speed hoist | | Drum rope capacity (ft) 15 in drum | |
|-----------------|-------------------------------------|-----------------------|---------------------------------------|-------|
| | Low Available lb* | High Available lb* | Layer | Total |
| 1 | 20,250 | 9610 | 101 | 101 |
| 2 | 18,490 | 8770 | 110 | 211 |
| 3 | 17,010 | 8070 | 120 | 331 |
| 4 | 15,750 | 7470 | 129 | 460 |
| 5 | 14,660 | 6960 | 139 | 599 |

*Max. lifting capacity: 6x37 or 35x7 class = 16,800 lb

Working area diagram

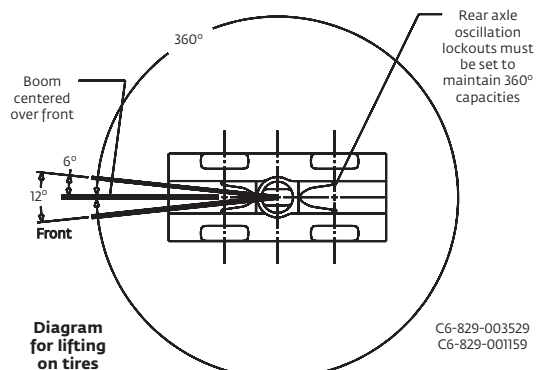
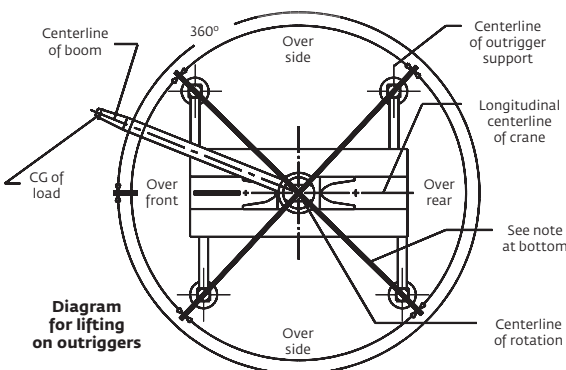

Bold lines determine the limiting position of any load for operation within working areas indicated.

THIS CHART IS ONLY A GUIDE AND SHOULD NOT BE USED TO OPERATE THE CRANE.

The individual crane's load chart, operating instructions and other instructional plates must be read and understood prior to operating the crane.

Notes

Manitowoc Cranes

Regional headquarters

Americas

Manitowoc, Wisconsin, USA

Tel: +1 920 684 6621

Fax: +1 920 683 6277

Shady Grove, Pennsylvania, USA

Tel: +1 717 597 8121

Fax: +1 717 597 4062

Europe, Middle East, Africa

Ecully, France

Tel: +33 (0)4 72 18 20 20

Fax: +33 (0)4 72 18 20 00

China

Shanghai, China

Tel: +86 21 6457 0066

Fax: +86 21 6457 4955

Greater Asia-Pacific

Singapore

Tel: +65 6264 1188

Fax: +65 6862 4040

Regional offices

Americas

Brazil

Alphaville

Mexico

Monterrey

Chile

Santiago

Europe, Middle East,

Africa

Czech Republic

Netvorice

France

Baudemont

Cergy

Decines

Germany

Langenfeld

Hungary

Budapest

Italy

Lainate

Netherlands

Breda

Poland

Warsaw

Portugal

Baltar

Russia

Moscow

U.A.E.

Dubai

U.K.

Buckingham

China

Beijing

Chengdu

Guangzhou

Xian

Greater Asia-Pacific

Australia

Adelaide

Brisbane

Melbourne

Sydney

India

Calcutta

Chennai

Delhi

Hyderabad

Pune

Korea

Seoul

Philippines

Makati City

Singapore

Factories

Brazil

Alphaville

China

TaiAn

Zhangjiagang

France

Charlieu

Moulins

Germany

Wilhelmshaven

India

Pune

Italy

Niella Tanaro

Portugal

Baltar

Fânzeres

Slovakia

Saris

USA

Manitowoc

Port Washington

Shady Grove

This document is non-contractual. Constant improvement and engineering progress make it necessary that we reserve the right to make specification, equipment, and price changes without notice. Illustrations shown may include optional equipment and accessories and may not include all standard equipment.